

TL12V-2 COMPACT TRACK LOADER



Rated Operating Capacity • 1865kg
Operating Weight • 5985kg

TL12V-2 Compact Track Loader

Takeuchi introduced the world's first compact track loader in 1986, engineered from the tracks up as an innovative solution for soft ground conditions and viable alternative to wheeled loaders.

This proven high-performance range of compact track loaders is now available from Takeuchi UK delivering excellent travel performance, traction, productivity and attachment versatility on any site.

The TL12V-2 combines all the proven characteristics of Takeuchi Compact Equipment: smooth hydraulics, power performance, proven durability with maximum operator comfort and serviceability.

POWER PERFORMANCE

The TL12V-2 with vertical lift design offers greater rated operating capacity for loading with extended dump reach.

Performance features include massive loader arms, oversized lift cylinders and pins to deliver maximum power performance on-site.

With high-flow as standard for specialist attachments and a 14-pin connector for greater versatility when using electro-hydraulic controlled attachments such as planers, mulchers and augers. The reinforced arm cross member provides rigid strength when operating heavy-duty attachments.

The TL12V-2 features a powerful 81.8kW engine that includes the very latest in low emissions, delivering outstanding power and torque in the most demanding applications.



COMFORT AND CONTROL

The TL12V-2 features a spacious wide operator station with a colour multi-information display, rear view camera and convenient rocker switches to control a wide range of functions.

The quiet ride track design enhances operator comfort by reducing vibration and sound suppression for lower noise levels.

The dial and foot throttle combined with pilot controls deliver smooth precision operating for long hours on the job site.

Protection of operators is integral to the design, with an all-steel cab, safe entry and exit points and easy access overhead door design. The full ROPS /TOPS, roof guard and LED work lights on the front and rear of the machine all add to safety on site.



Pilot Operated Controls



Battery Access Panel



Lower Cross Member & Step



Oversized Lift Cylinders

TL12V-2 STRENGTH IN DESIGN

POWER PERFORMANCE

Delivers outstanding breakout force and lift capacity for a compact track loader

TOTAL RELIABILITY

Precision engineering from Japanese craftsmanship – Built to last

ALL STEEL HEAVY DUTY PROTECTION

In every part of the machine

MAXIMUM VISIBILITY

Rear view camera and lower cross members for safe on-site working

UNRIVALLED SERVICE ACCESS

All at ground level with swing out cooler frame and tilt-up cab



EASY SERVICE

The tilt-up cab delivers maximum access to the primary and secondary fuel filters, DPF, pilot filter, pump group, and control valve.

The heavy-duty rear door protects vital engine components and swings out to access the side-by-side cooling module and clustered service points.

The rear towers house additional easy access service points.



Multi-Information Display



12V Accessory Outlet



LED Work Lights



Multi-Function Switch

PRODUCT FEATURES

(see website for the complete features list)

SPACIOUS OPERATOR STATION



- 5.7" multi-functional colour display
- High back adjustable suspension seat
- 3-point seat belt
- Rear pivoting seat bar with integrated arm rests
- Pilot operated controls
- A/C, heat, defrost
- Rear view camera
- Front wiper
- AM / FM radio / Bluetooth
- Pressurised cab with roll-up door
- Tilt-up cab
- ROPS/FOPS structure
- FOPS level II roof guard

HIGH POWER ENGINE



- EU Stage V compliant
- Turbocharged and intercooled
- DOC+DPF+SCR exhaust after treatment
- Active power control system
- Working modes - Power and ECO
- Dial and foot throttle control
- Automatic fuel bleed system
- High-capacity radiator, hydraulic oil cooler and intercooler mounted side-by-side on swing out frame
- Double element air cleaner

PRECISE CONTROLLED HYDRAULICS



- Vertical lift loader design
- Cushioned arm cylinders
- Arm float
- Hydraulic pilot controls
- Proportional auxiliary controls with detent
- Flat faced coupler body and pressure relieving system
- Hydraulic self-leveling
- Hydraulic quick hitch
- 14-pin connector
- Primary flow - aux circuit 88 l/min
- High flow - aux circuit 153 l/min
- OPTIONAL 2nd flow - aux 88 l/min
- Ride control

ERGONOMIC ELECTRIC CONTROL



- LED work lights: two front / two rear
- Sealed rocker switches
- 12V system with 80A alternator
- Hour meter
- Engine preheat
- Heavy duty, easy access battery
- Reverse alarm
- Horn

ROBUST TRACK FRAME



- 450mm quiet ride track design
- Long track frame
- Grease type track adjuster
- Fully welded frame with integrated cross members
- Rear bumper integrated into frame
- Front and rear tie-down and lift points
- Permanently sealed track rollers with metal face seals
- Double reduction planetary drives
- 2-speed travel with automatic shift down
- Switch activated parking brake

TAKEUCHI FLEET MANAGEMENT



TFM is a remote **TELEMATICS** system, using real time data to better manage your fleet and lower overall operating costs.

- FREE 5 Year standard service
- Downtime prevention
- Remote diagnostics
- Utilisation tracking
- Proactive maintenance
- Control costs



FREE 5-YEAR
TAKEUCHI FLEET
MANAGEMENT



3-YEAR
3,000 HOUR

WARRANTY AS STANDARD*



POWER, PERFORMANCE, PEACE OF MIND

TL12V-2 COMPACT TRACK LOADER



TAKEUCHI COMPACT TRACK LOADERS - VERSATILE & ATTACHMENT READY

- AUGERS
- BRUSH CUTTERS
- GRADERS
- MULCHERS
- PALLET FORKS
- RAKES
- RIPPER
- ROAD PLANER
- SWEEPERS
- STUMP GRINDER
- TRENCHERS
- 4 in 1 BUCKETS

TL12V-2 COMPACT TRACK LOADER

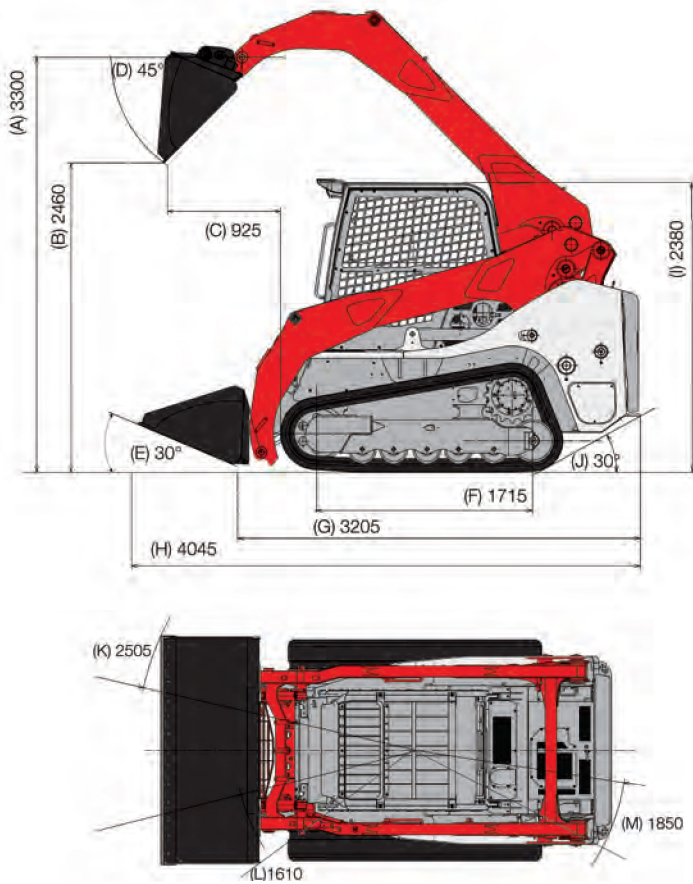

All dimensions unless otherwise stated are in millimetres.

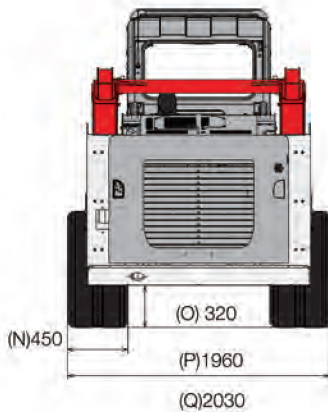

**FULL
3-YEAR
3,000 HOUR*
WARRANTY**

Takeuchi machines come with a full 3 year/3000 hours warranty as standard, terms and conditions apply* see website.

Before fitment of a hydraulic attachment, machine auxiliary pressure and flow should be accurately measured. For all lifting specifications please refer to the lift charts on the Takeuchi website or operator manual.

In accordance with our established policy of constant improvement, we reserve the right to amend these specifications at any time without notice. Photographs shown may feature non-standard equipment.

TL12V-2

Standard UK Specification: Cab / Vertical Lift / Rubber Tracks

Engine	
Make	KUBOTA
Model	V3800
Engine Displacement (cc)	3769
Rated Output (kW) / rpm	81.8 / 2400
Maximum Torque (Nm)	379.3

Fluid Capacities	
Engine Lubrication (l)	13.2
Cooling System (l)	18
Diesel Exhaust Fluid (DEF) (l)	18
Fuel Tank Capacity (l)	119.5
Hydraulic Reservoir Capacity (l)	50
Hydraulic System Capacity (l)	78

Operating Performance	
Operating Weight - Cab (kg)	5985
Tipping Load (kg)	5325
Rated Operating Capacity (ISO 14397-1) @ 35%* (kg)	1865
Operating Load @ 50% of Tip Load (kg)	2663
Bucket Breakout Force (kN)	35
Lift Arm Breakout Force (kN)	31.6
Traction Force (kN)	62.3
Ground Pressure (kPa)	34.3
Travel Speed Low / High (km/h)	8.1 / 11.8

Hydraulics	
Primary flow - auxiliary circuit (l/min)	88
High flow - auxiliary circuit (l/min)	153
OPTIONAL - 2nd flow - auxiliary circuit - (l/min)	88
Hydraulic System Pressure (MPa)	24

Machine Dimensions		
A	Max. Lift Height to Bucket Pin (mm)	3300
B	Dump Height Fully Raised (mm)	2460
C	Dump Reach Fully Raised (mm)	925
D	Dump Angle	45°
E	Rollback Angle	30°
F	Track Ground Contact Length (mm)	1715
G	Machine Length (mm)	3205
H	Transport Length (mm)	4045
I	Transport Height with Roof Guard (mm)	2380
J	Departure Angle	30°
K	Clearance Circle with Bucket (mm)	2505
L	Clearance Circle without Bucket (mm)	1610
M	Clearance Circle Rear (mm)	1850
N	Track Width (mm)	450
O	Ground Clearance (mm)	320
P	Overall Width without Bucket (mm)	1960
Q	Overall Width with Bucket (mm)	2030

Health & Safety	
Noise / Sound Power Level (LWA)	104db
Vibration Hand - Arm / Body m/sec ²	<2.5 / <0.5

*Rated Operating Capacity of track loaders is rated according to ISO 14397-1 at no more than 35% of the tipping load.

08/2025

For more information locally contact:



SCAN ME

To find your local dealer

Takeuchi Mfg (UK) Ltd, Unit E2B Kingsway Business Park, John Boyd Dunlop Drive, Rochdale, Lancashire OL16 4NG
info@takeuchi-mfg.co.uk www.takeuchi-mfg.co.uk

@TakeuchiUK

TAKEUCHI
From World First to World Leader