

# TL10V-2 COMPACT TRACK LOADER



Rated Operating Capacity • 1145kg  
Operating Weight • 4660kg

# TL10V-2 Compact Track Loader

Takeuchi introduced the world's first compact track loader in 1986, engineered from the tracks up as an innovative solution for soft ground conditions and viable alternative to wheeled loaders.

This proven high-performance range of compact track loaders is now available from Takeuchi UK delivering excellent travel performance, traction, productivity and attachment versatility on any site.

The TL10V-2 combines all the proven characteristics of Takeuchi Compact Equipment: smooth hydraulics, power performance, proven durability with maximum operator comfort and serviceability.



## COMFORT AND CONTROL

The TL10V-2 features a spacious wide operator station with a colour multi-information display, rear view camera and convenient rocker switches to control a wide range of functions.

The quiet ride track design enhances operator comfort by reducing vibration and sound suppression for lower noise levels.

The dial and foot throttle combined with pilot controls deliver smooth precision operating for long hours on the job site

Protection of operators is integral to the design, with an all-steel cab, safe entry and exit points and unique overhead door design. The full ROPS /TOPS, roof guard and LED work lights on the front and rear of the machine all add to safety on site.

## POWER PERFORMANCE

The TL10V-2 with vertical lift design offers greater rated operating capacity for loading with extended dump reach.

Performance features include massive loader arms, oversized lift cylinders and pins to deliver maximum power performance on-site.

With high-flow as standard for specialist attachments and a 14-pin connector for greater versatility when using electro-hydraulic controlled attachments such as planers, mulchers and augers. The reinforced arm cross member provides rigid strength when operating heavy-duty attachments.

The TL10V-2 features a powerful 54.6kW engine that includes the very latest in low emissions, delivering outstanding power and torque performance in the most demanding applications.



Multi-Information Display



Rear View Camera



LED Work Lights

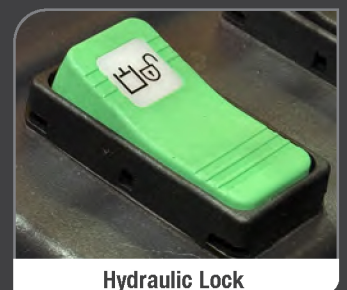

Hydraulic Lock

# TL10V-2 STRENGTH IN DESIGN

## POWER PERFORMANCE

Delivers outstanding breakout force and lift capacity for a compact track loader

## TOTAL RELIABILITY

Precision engineering from Japanese craftsmanship – Built to last

## MAXIMUM VISIBILITY

Rear view camera and lower cross members for safe on-site working

## ALL STEEL HEAVY DUTY PROTECTION

In every part of the machine



## UNRIVALLED SERVICE ACCESS

All at ground level with swing out cooler frame and tilt-up cab

## EASY SERVICE

The tilt-up cab delivers maximum access to the primary and secondary fuel filters, DPF, pilot filter, pump group, and control valve.

The heavy-duty rear door protects vital engine components and swings out to access the side-by-side cooling module and clustered service points.

The rear towers house additional easy access service points.



Pilot Operated Controls



Battery Access Panel



Lower Cross Member & Step



Oversized Lift Cylinders

# PRODUCT FEATURES

(see website for the complete features list)

## SPACIOUS OPERATOR STATION



- 5.7 multi-informational colour display
- Adjustable high back suspension seat
- Rear pivoting seat bar with integrated arm rest
- 3-point retractable seat belt
- A/C, heat, defrost
- Front wiper
- Rear View Camera
- AM / FM radio, Bluetooth
- Pressurised cab with roll-up door
- Tilt-up cab
- ROPS / FOPS structure
- FOPS Level II roof guard kit

## HIGH POWER ENGINE



- EU Stage V compliant
- Turbocharged
- High pressure common rail injection system
- DOC+DPF exhaust after treatment
- Automatic fuel bleed system
- Active power control system
- Working modes - Power and ECO
- Double element air cleaner
- Dial and foot throttle control
- High capacity radiator, hydraulic oil cooler mounted side-by-side on swing out frame

## PRECISE CONTROLLED HYDRAULICS



- High lift vertical lift arm design
- Hydraulic pilot controls
- Arm float
- Cushioned arm cylinders
- Hydraulic self leveling
- Proportional auxiliary hydraulic controls with detent
- Flat faced coupler body and pressure relieving system
- 14-pin connector push button
- High capacity steel hydraulic tank
- Hydraulic quick hitch
- Primary flow - aux circuit 71 l/min
- High flow - aux circuit 124 l/min
- OPTIONAL - 2nd flow aux 71 l/min
- Ride control

## ERGONOMIC ELECTRIC CONTROL



- LED work lights: two front / two rear
- Sealed rocker switches
- 12V system with 60A alternator
- Engine preheat
- Hour meter
- Reverse alarm
- Horn
- Heavy duty easy access battery

## ROBUST TRACK FRAME



- 400mm quiet ride track design
- Double reduction planetary drives
- Permanently sealed track rollers with metal face seals
- Fully welded frame with integrated cross members
- 2-speed travel with automatic shift down
- Long track frame
- Grease type track adjuster
- Front and rear tie-down points and lift points
- Rear bumper integrated into frame
- Switch Activated Parking Brake

## TAKEUCHI FLEET MANAGEMENT



**TFM** is a remote **TELEMATICS** system, using real time data to better manage your fleet and lower overall operating costs.

- FREE 5 Year standard service
- Downtime prevention
- Remote diagnostics
- Utilisation tracking
- Proactive maintenance
- Control costs



**FREE 5-YEAR**  
**TAKEUCHI FLEET**  
**MANAGEMENT**

**3-YEAR**  
**3,000 HOUR**  
WARRANTY AS STANDARD\*



**POWER, PERFORMANCE, PEACE OF MIND**

# TL10V-2 COMPACT TRACK LOADER



## TAKEUCHI COMPACT TRACK LOADERS - VERSATILE & ATTACHMENT READY

- AUGERS
- BRUSH CUTTERS
- GRADERS
- MULCHERS
- PALLET FORKS
- RAKES
- RIPPER
- ROAD PLANER
- SWEEPERS
- STUMP GRINDER
- TRENCHERS
- 4 in 1 BUCKETS

# TL10V-2 COMPACT TRACK LOADER

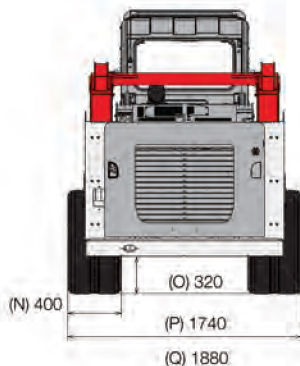
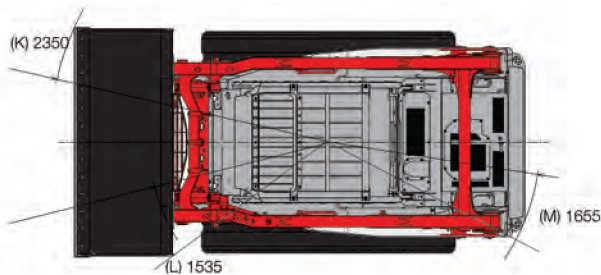
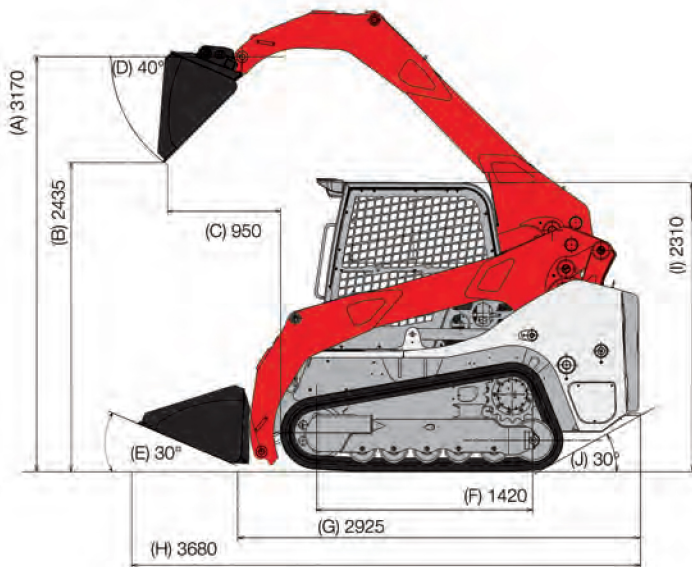

All dimensions unless otherwise stated are in millimetres.

## TL10V-2

Standard UK Specification: Cab / Vertical Lift / Rubber Tracks

Engine	
Make	KUBOTA
Model	V3307
Engine Displacement (cc)	3331
Rated Output (kW) / rpm	54.6 / 2600
Maximum Torque (Nm)	261.1
Fluid Capacities	
Engine Lubrication (l)	11.2
Cooling System (l)	15
Fuel Tank Capacity (l)	81
Hydraulic Reservoir Capacity (l)	36
Hydraulic System Capacity (l)	65
Operating Performance	
Operating Weight - Cab (kg)	4660
Tipping Load (kg)	3270
Rated Operating Capacity (ISO 14397-1) @ 35%* (kg)	1145
Operating Load @ 50% of Tip Load (kg)	1635
Bucket Breakout Force (kN)	29
Lift Arm Breakout Force (kN)	24
Traction Force (kN)	43.3
Ground Pressure Cab (kPa)	35.9
Travel Speed Low / High (km/h)	7.7 / 11.3
Hydraulic System	
Auxiliary Flow - Primary Circuit (l/min)	71
Auxiliary Flow - High Flow (l/min)	124
Optional - Auxiliary Flow - 2nd Circuit (l/min)	71
Hydraulic System Pressure (MPa)	24
Machine Dimensions	
A Max. Lift Height to Bucket Pin (mm)	3170
B Dump Height Fully Raised (mm)	2435
C Dump Reach Fully Raised (mm)	950
D Dump Angle	40°
E Rollback Angle	30
F Track Ground Contact Length (mm)	1420
G Machine Length (mm)	2925
H Transport Length (mm)	3680
I Transport Height with Roof Guard (mm)	2310
J Departure Angle	30°
K Clearance Circle with Bucket (mm)	2350
L Clearance Circle without Bucket (mm)	1535
M Clearance Circle Rear (mm)	1655
N Track Width (mm)	400
O Ground Clearance (mm)	320
P Overall Width without Bucket (mm)	1740
Q Overall Width with Bucket (mm)	1880
Health & Safety	
Noise / Sound Power Level (LWA)	103db
Vibration Hand - Arm / Body m/sec <sup>2</sup>	<2.5 - <0.5

\*Rated Operating Capacity of track loaders is rated according to ISO 14397-1 at no more than 35% of the tipping load.

08/2025

**FULL  
3-YEAR  
3,000 HOUR\*  
WARRANTY**

Takeuchi machines come with a full 3 year/3000 hours warranty as standard, terms and conditions apply\* see website.

Before fitment of a hydraulic attachment, machine auxiliary pressure and flow should be accurately measured. For all lifting specifications please refer to the lift charts on the Takeuchi website or operator manual.

In accordance with our established policy of constant improvement, we reserve the right to amend these specifications at any time without notice. Photographs shown may feature non-standard equipment.

For more information locally contact:



SCAN ME

To find your local dealer

Takeuchi Mfg (UK) Ltd, Unit E2B Kingsway Business Park, John Boyd Dunlop Drive, Rochdale, Lancashire OL16 4NG  
info@takeuchi-mfg.co.uk www.takeuchi-mfg.co.uk

@TakeuchiUK



**TAKEUCHI**  
From World First to World Leader